

System/ Components Page: Meters and Manifolds

Manifolds



14 Port Manifold

Grease runs from the pump through the mainline to each manifold. It enters each meter and is then dispersed in different quantities (depending on the meter size) to the grease point through a secondary line.

The grease will continue from this manifold to the next through a second mainline connection on the opposite end of the manifold, until it is closed off with an end plug.

Manifolds are made of high quality, corrosion resistant bronze and can hold 4,7,9,12 or 14 meters. Other combinations are possible using meter plugs.

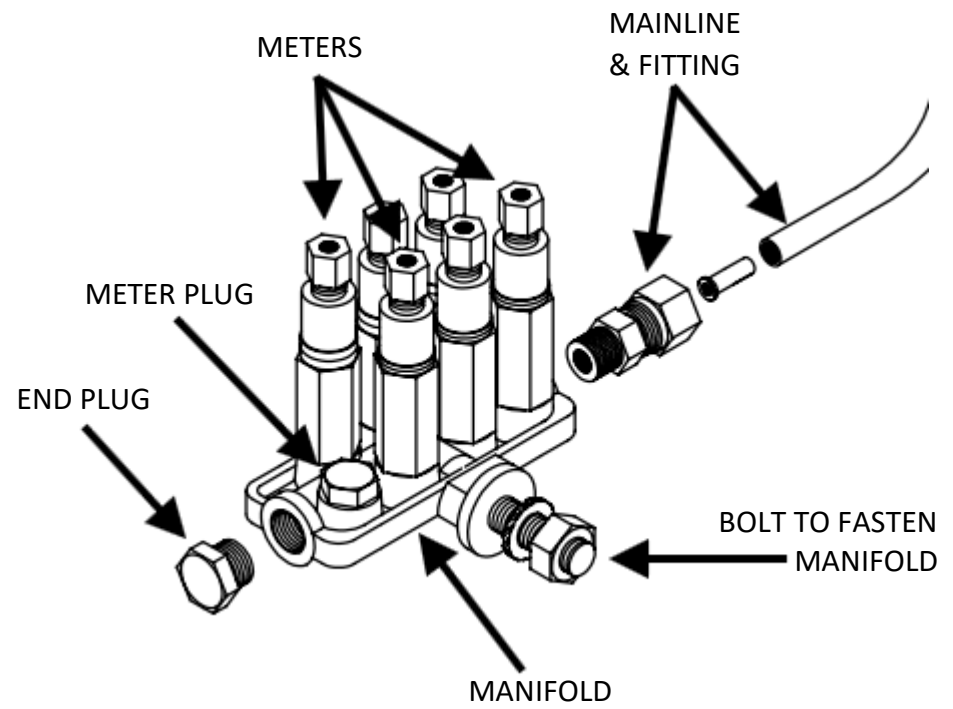

Meters (aka "Injectors")

One end of each meter is fastened to the manifold. The other end is fitted to a 3/16th secondary line. This is where the grease exits through the line to the grease point. The amount of grease is dictated by the size of the meter; larger meters = more grease, smaller meters = less grease.

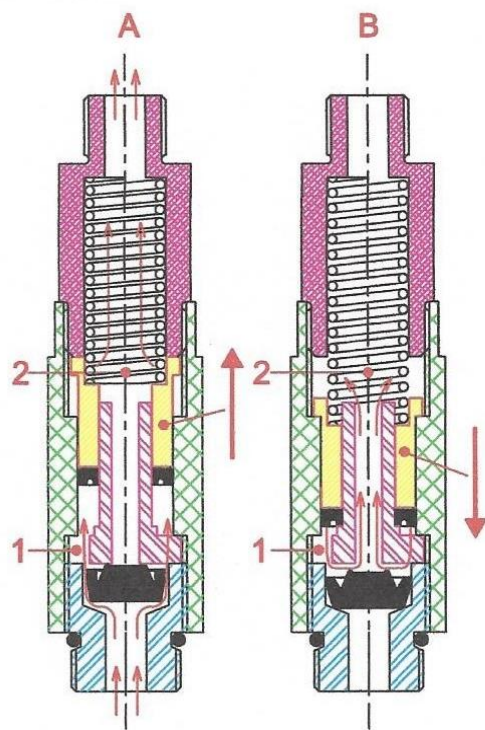
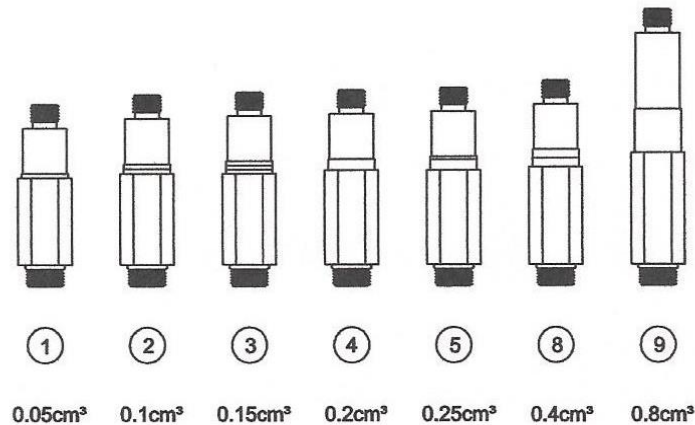

Figure A

- Grease is pumped into area 1 via the main tubing against the spring.
- The grease in area 2 is then pumped to the lubrication points.

Figure B

- When the grease pressure falls away, the grease in area 1 will disperse to area 2 by means of the spring.



(from Ecostar Manual, Ed 12/12)

* The meters require downtime in between pulses in order to refill/repressurize with grease. It is important for the timer to be set correctly to allow for this 'downtime.'



The size of the meter (1-9) is determined by looking at the rings between the hex body and cylindrical top.

The engraving or stamping on the meter is a factory date code and part number:

070 - 040 - 0070 = #1 meter
 070 - 040 - 0080 = #2 meter
 070 - 040 - 0090 = #3 meter
 070 - 040 - 0100 = #4 meter
 070 - 040 - 0110 = #5 meter
 070 - 040 - 0140 = #8 meter
 070 - 040 - 0250 = #9 meter